

DRAFT
RECOMMENDATION

TC 16/SC 1
(NL+RU)

SUBMITTED
FOR DIRECT
CIML ONLINE
APPROVAL

**Instruments for continuous measuring SO₂
in stationary source emissions**

*Draft submitted for
direct CIML online approval on 2009.02.18.
Voting closes on 2009.05.15.*



Contents

<i>Foreword</i>	
1 Scope	X
2 Terminology	X
3 Description of the gas analytical system	X
4 Metrological requirements	X
5 Technical requirements	X
6 Operating manual	X
7 Metrological controls	X
8 Performance tests for type approval	X
Annex A Performance tests for type approval (Mandatory)	X
Annex B Designation of calibration gas mixtures and their composition (Mandatory)	X
Annex C Procedure for initial verification (Mandatory)	X
Annex D Procedure for subsequent verification (Informative)	X
Annex E Procedure for gas analytical system control under operating conditions (Informative)	X
Annex F Evaluation Report Format	X
Annex G Bibliography	X

Foreword

The International Organization of Legal Metrology (OIML) is a worldwide, intergovernmental organization whose primary aim is to harmonize the regulations and metrological controls applied by the national metrological services, or related organizations, of its Member States. The main categories of OIML publications are:

- **International Recommendations (OIML R)**, which are model regulations that establish the metrological characteristics required of certain measuring instruments and which specify methods and equipment for checking their conformity. OIML Member States shall implement these Recommendations to the greatest possible extent;
- **International Documents (OIML D)**, which are informative in nature and which are intended to harmonize and improve work in the field of legal metrology;
- **International Guides (OIML G)**, which are also informative in nature and which are intended to give guidelines for the application of certain requirements to legal metrology; and
- **International Basic Publications (OIML B)**, which define the operating rules of the various OIML structures and systems.

OIML Draft Recommendations, Documents and Guides are developed by Technical Committees or Subcommittees which comprise representatives from the Member States. Certain international and regional institutions also participate on a consultation basis. Cooperative agreements have been established between the OIML and certain institutions, such as ISO and the IEC, with the objective of avoiding contradictory requirements. Consequently, manufacturers and users of measuring instruments, test laboratories, etc. may simultaneously apply OIML publications and those of other institutions.

International Recommendations, Documents, Guides and Basic Publications are published in English (E) and translated into French (F) and are subject to periodic revision.

Additionally, the OIML publishes or participates in the publication of **Vocabularies (OIML V)** and periodically commissions legal metrology experts to write **Expert Reports (OIML E)**. Expert Reports are intended to provide information and advice, and are written solely from the viewpoint of their author, without the involvement of a Technical Committee or Subcommittee, nor that of the OIML. Thus, they do not necessarily represent the views of the OIML.

This publication - reference OIML R XX, Edition 200X - was developed by Technical Subcommittee TC 16/SC 1 *Air pollution*. It was approved for final publication by the International Committee of Legal Metrology in 200X and will be submitted to the International Conference of Legal Metrology in 2012 for formal sanction.

OIML Publications may be downloaded from the OIML web site in the form of PDF files. Additional information on OIML Publications may be obtained from the Organization's headquarters:

Bureau International de Métrologie Légale
11, rue Turgot - 75009 Paris - France
Telephone: 33 (0)1 48 78 12 82
Fax: 33 (0)1 42 82 17 27
E-mail: biml@oiml.org
Internet: www.oiml.org

Instruments for continuous measuring SO₂ in stationary source emissions

1 Scope

1.1 This Recommendation applies to measuring instruments (hereafter referred to as “gas analytical systems”) that serve to determine the volume fraction of SO₂ and establishes the conditions and requirements with which such systems shall comply in order to meet the requirements for measurement results of the pollutant content in stationary source emissions within the OIML Member States.

This Recommendation applies to gas analytical systems intended for measuring (analyzing) emissions of industrial enterprises and to gas analytical systems for controlling the technological processes whose principle of operation is based on UV absorption, fluorescence or nondispersive IR methods. It specifies the metrological and technical requirements for gas analytical systems, as well as the means and methods for checking their standardized characteristics.

1.2 Restrictions

1.2.1 This Recommendation does not consider the uncertainties of the measurement results of the emissions to be determined on the spot where the gas analytical system is actually installed; these uncertainties are determined by the primary standard method on the second level of quality assurance.

1.2.2 Gas analytical system software certification problems are also beyond the scope of this Recommendation.

2 Terminology

2.1 gas analytical system

assembly to carry out specified gas analytical measurements (ISO 7504:2001 [22])

Note: In this Recommendation a gas analytical system means a system that continuously measures the volume fraction of sulfur dioxide by analyzing the gas samples taken directly from the pipe or gas duct of an industrial enterprise, which includes a means for sampling and sample preparation (in the case of extractive sampling), a gas analyzer, means for accumulation, processing and storage of measurement results, means for control and adjustment of the main components of the system, an interface to connect devices measuring the gas flow parameters of exhaust emissions, and gas and electric lines of communication.

2.2 sampling probe

device inserted into the gas, designed to take a representative sample thereof, to which a sample line or a sample container is connected (ISO 7504: 2001 [22])

2.3 Sampling techniques (ISO 7504:2001 [22])

2.3.1 sample line

line provided to remove a representative sample of a gas to be analyzed and to transport it to the analyzer

Note: A sample line may include devices such as filters, dryers or condensers (primary and secondary treatment gas) which are necessary to prepare the sample for analysis.

2.4 gas analyzer

assembly which enables qualitative and/or quantitative determinations (measurements) of substances on the basis of their chemical or physical properties (ISO 7504: 2001 [22])

2.5 input measurement signal

measurement signal functionally related to the measurand – the volume fraction of a component to be measured, which enters the input of a measuring instrument, a measuring channel or a separate converter component

2.6 gas handling system

all components of the gas analytical system, from the sampling probe to the tube of the gas sample outlet, through which the gas samples, including the Calibration Gas Mixture (hereafter termed “CGM”) and the zero gas, are conveyed by the pump

2.7 adjustment

set of operations carried out on a measuring system so that it provides prescribed indications corresponding to given values of a quantity to be measured (VIM, 3.11 [1])

2.7.1 user adjustment

adjustment employing only the means at the disposal of the user

2.7.2 adjustment means

means allowing the adjustment of the gas analytical system by the user

2.7.3 semi-automatic adjustment means

means allowing the user to adjust the gas analytical system without having the possibility of changing the input measurement signal, whether the automatic adjustment is required or not

Note: For those gas analytical systems that require the calibration gas mixture to be entered manually, the adjustment means are considered to be semi-automatic.

2.7.4 automatic adjustment means

means performing the adjustment of the gas analytical system as programmed without the intervention of the user, to initiate the adjustment or regulate the measurement signal

2.8 zero-setting means (of a gas analyzer)

means to set the indication of the gas analyzer to zero

2.9 means for adjustment of a gas analyzer by the calibration gas mixture

means to adjust the indication of the gas analyzer to the value of the SO₂ volume fraction in a CGM

2.10 internal adjustment means

means to adjust the gas analyzer without the use of a CGM

2.11 warm-up time

time between the instant at which power is applied to a gas analytical system and the instant at which the system is capable of complying with the metrological requirements

Note: For a gas analyzer this is the time between the instant at which power is applied to it and the instant at which the measurement result of the volume fraction, a CGM being supplied to the input, is within the permissible limits.

2.12 response time

time interval between the instant of a stepwise concentration change of the substance (SO₂) being measured and the instant at which the signal reaches 90 % of its stable value

2.13 error

measured quantity value minus a reference quantity value (VIM, 2.16 [1])

2.14 intrinsic error

error of a gas analyzer, determined under reference conditions

2.15 absolute error of measurement

result of measurement minus a true value of the measurand

2.16 relative error

error of measurement divided by the conventional true value of the measurand

2.17 fault

difference between the error of indication and the intrinsic error of measuring instrument (OIML D 11:2004, 3.9 [6])

Note: Random errors presenting momentary variations in the indication but which cannot be interpreted, recorded or transmitted as measuring results are considered to be insignificant faults.

2.18 influence quantity

quantity that, in a direct measurement, does not affect the quantity that is actually measured, but that affects the relation between the indication and the measurement result (VIM, 2.52 [1])

2.19 rated operating conditions

operating conditions that must be fulfilled during measurement in order that a measuring instrument or measuring system perform as designed (VIM, 4.9 [1])

2.20 disturbance

influence quantity having a value within the limits specified in this Recommendation but outside the specified rated operating conditions of a measuring instrument (OIML D 11:2004, 13.2 [6])

2.21 reference condition

operating condition prescribed for evaluating the performance of a measuring instrument or measuring system or for comparison of measurement results (VIM, 4.11 [1])

2.22 checking facility

facility that is incorporated in a measuring instrument and which enables significant faults to be detected and acted upon

Note: “Acted upon” refers to any adequate response by the measuring instrument (luminous signal, acoustic signal, prevention of the measurement process, etc.) (OIML D 11:2004, 3.18 [1]).

2.23 gas sample

gas taken from the pipe or gas duct of the stationary source of emissions, conveyed to the gas analyzer for analysis

2.24 instrumental drift

continuous or incremental change over time in the indication, due to changes in the metrological properties of a measuring instrument. (VIM, 4.21 [1])

Note: In this Recommendation, “drift” means a change in the indication which occurs during a stated period of time at a given concentration of SO₂ in a sample to be analyzed.

2.25 calibration gas mixture (CGM)

stable gas mixture of known SO₂ concentration (volume fraction) used for periodic calibration and adjustment of the gas analyzer, as well as for tests of its metrological characteristics for compliance with the requirements of normative documents

2.26 Abbreviations

AC	Alternating Current
DC	Direct Current
CGM	Calibration Gas Mixture
EM	Electromagnetic
EUT	Equipment Under Test
IEC	International Electrotechnical Commission
ISO	International Organization for Standardization
MPE	Maximum Permissible Error
ppm	part per million (e.g. 1 cm ³ /1 m ³) (ISO 31-8 [24])

3 Description of the gas analytical system

3.1 The gas analytical system for extractive methods consists of a means for sampling, preparation of samples, and measurement of the SO₂ concentration in the pipes and gas ducts of industrial enterprises. The pump provides the means for conveying the gas sample through a gas handling system. The SO₂ gas analyzer incorporated in the gas handling system analyzes the sample and provides a signal related to the volume fraction of the gas component of interest (SO₂), which arrives at the data accumulation unit where it is processed, recorded and stored.

The metrological characteristics of the gas analytical system depend on the corresponding characteristics of the units included. The example of the composition of a gas analytical system using calibration gas mixtures for its adjustment is shown in Fig.1.

3.2 The gas analytical system in general consists of the following principle units:

- a sampling probe with a coarse filter, which is introduced into the pipe or gas duct of a stationary source of emissions;
- a heated main pipe for supplying a gas sample from the sampling probe to the input of the gas analyzer;
- a pump to convey the gas sample through the gas handling system;
- a gas flow rate measurement system, for example a rotameter, to measure the gas flow rate in the gas handling system;
- a condensate separator to prevent condensation from forming in the gas handling system;
- a filter to remove dust from the gas sample, which could cause contamination of various inner parts of the gas analyzer;
- an electro-pneumatic valve to switch a sample to be analyzed, a calibration gas mixture or a zero gas to the input of the SO₂ gas analyzer (a pipe connecting two three-way valves is intended for delivering the CGM to a sampling system through a three-way valve to estimate the efficiency of that system, i.e. the absence of probe composition change);
- a gas analyzer;
- a means to check operation of the gas analytical system and means to adjust the units;
- a means for data accumulation, processing and storage.

The gas analytical system may include means to signal:

- the malfunction of the units of the gas analytical system;
- the reduction of the gas amount in a cylinder required for automatic adjustment of the gas analyzer to an amount below the permissible value; and
- the current value of the SO₂ volume fraction in the sample exceeding the maximum permissible value.

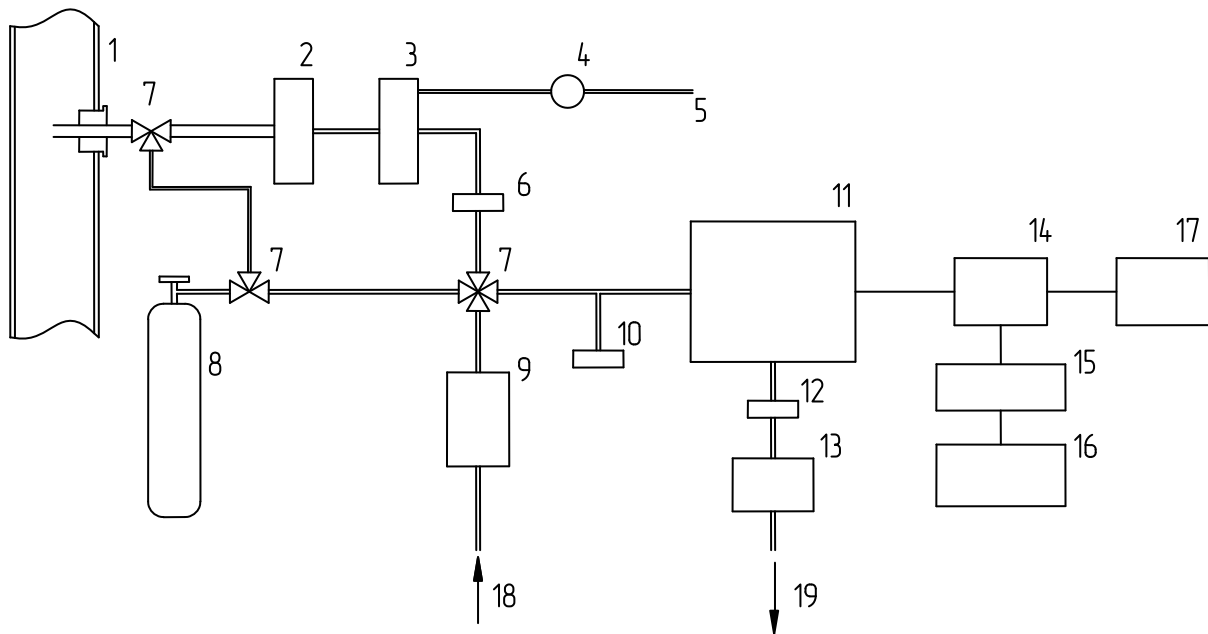

Fig. 1

Example of the composition of a gas analytical system using calibration gas mixtures for its adjustment

Figure labels

- | | |
|----------------------------|---|
| 1. Pipe | 11. Gas analyzer |
| 2. Sampling probe | 12. Rotameter |
| 3. Separator | 13. Pump |
| 4. Compressor | 14. Processing and information storage unit |
| 5. Condensate removal | 15. Adjustment means |
| 6. Filter | 16. Unauthorized adjustment protection |
| 7. Electro-pneumatic valve | 17. Interfaces |
| 8. CGM cylinder | 18. Zero gas input |
| 9. Carbon filter | 19. Sample output |
| 10. Pressure sensor | |

4 Metrological requirements

4.1 Presentation of the measurement results

The measurement results of the concentration of sulfur dioxide in the sample shall be obtained as its volume fraction in the mixture of gases selected from the stationary source emissions, calculated for reference conditions.

The reference conditions are:

- temperature: 273.15 K;
- pressure: 101.3 kPa.

In this Recommendation for the volume fraction unit, ppm is used (ISO 31-8 [24]).

4.2 Measuring range

The gas analyzer shall be capable of measuring the volume fraction of sulfur dioxide over a range from 1 ppm to 5 000 ppm. This measuring range may be divided into sub-ranges.

4.3 Maximum permissible errors

4.3.1 Maximum permissible intrinsic error

For any measurement within the measuring range or sub-range (see 4.2) under the reference conditions specified in 8, the MPE, positive or negative, is the larger of the two following values:

- 0.5 ppm;
- 5 % of the measured value.

4.3.2 Maximum permissible errors on verification under rated operating conditions (without dismantling the gas analytical system)

The MPE, positive or negative under the rated operating conditions specified in 4.5.1, may be equal to or greater than the maximum permissible intrinsic errors, taking into account the real values of the influence quantities, but they should not exceed the larger of the two following values:

- 1.2 ppm;
- 8 % of the measured value.

4.4 Repeatability

An estimate of the standard deviation is used as a characteristic of repeatability, which shall not exceed 1/3 of the maximum permissible intrinsic error (4.3.1) at the given point of the measuring range.

4.5 Influence quantities

4.5.1 Rated operating conditions (for use of the gas analyzer):

- a) temperature: 5 °C to 40 °C;
- b) relative humidity: up to 90 % at 25 °C;
- c) atmospheric pressure: from 86 kPa to 106 kPa;
- d) supply from AC power mains:
 - voltage: nominal value, with deviation from nominal value: – 15 %, + 10 %;
 - frequency: nominal value \pm 2 %.

If a battery is used to power the gas analyzer, the limits of power supplied shall be within the gas analyzer manufacturer's specifications. If a current generator is used, the limits of variation of the parameters shall comply with the specifications for the mains voltage.

Note 1: The above limiting values of temperature, relative humidity and atmospheric pressure under the rated operating conditions for use of the gas analyzer may be changed to extend the ranges.

Note 2: Instruments using a battery power supply should be equipped with an indicator to warn when the battery becomes discharged.

4.5.2 Influence of the gas components of emissions other than the measurand (cross sensitivity)

The indications of the gas analyzer shall not vary by more than half the modulus of the maximum permissible intrinsic error (4.3.1) at the given point of the measurement range if the value of the volume fraction of the gas components other than the measurand does not exceed the maximum permissible value.

Note: The manufacturer of the gas analytical system shall provide the list of gas components other than the measurand and their maximum permissible concentrations in the operating instructions.

4.5.3 Vibration

The gas analytical system shall be protected against the effects of vibration. The manufacturer shall indicate in the specifications the requirements for the vibration parameters, at which the metrological characteristics of the gas analyzer are within the permissible limits (4.3.2). The minimum requirements should correspond to severity level 1 of OIML D 11:2004, 11.1. [6].

Note: The requirements for the individual units of the gas analytical system may vary.

4.5.4 Disturbances

The error of the gas analyzer shall lie within the permissible limits, or its failure shall be detected by the checking facility for the following disturbances:

- a) mechanical shock;
- b) short time power reduction;
- c) voltage pulses from the mains;

- d) electrostatic discharges;
- e) radio frequency electromagnetic fields.

The disturbance norms and test methods are described in Annex A.

4.6 Response time

When a volume fraction of SO₂ at the input changes abruptly from 0 % to 100 %, the reading of the gas analyzer shall reach, within 4 minutes, a value of at least 90 %.

4.7 Warm-up time

After connecting the gas analytical system to the mains and after the warm-up time specified by the manufacturer of this system, it shall meet the metrological requirements stated in this Recommendation.

4.8 Stability with time or drift

In the case of semi-automatic adjustment of the gas analyzer, when it is operated in accordance with the operating instructions under stable environmental conditions, its error shall remain within the maximum permissible errors (according to 4.3.1) for at least 7 days from the moment of adjustment of the gas analyzer using the CGM. If the gas analyzer is equipped with a means for drift compensation, such as automatic zero correction or automatic internal adjustment, the action of these adjustments shall not produce any indication that can be confused with a concentration of measured sample.

5 Technical requirements

5.1 Construction

5.1.1 All components of the gas handling system shall be made of corrosion resistant material. The materials used shall not influence the composition of the gas sample.

5.1.2 The means for sampling and sample preparation during extractive sampling shall provide for representative sampling and shall comply with ISO 10396-2007 [23].

5.1.3 The gas handling system shall contain a switching system to allow for the zero gas, gas calibration mixtures and analyzed gas sample to flow into the analyzer.

A dehydrating charcoal filter or equivalent system shall be used when ambient air is supplied as a zero gas.

5.1.4 The pump conveying the gas sample shall be mounted so that its vibrations do not affect the measurement result. It shall be possible for the user to turn the pump on and off separately from the other components of the gas analytical system; however, it shall not be possible to make a measurement when the pump is switched off.

Note: It is recommended to flush the gas handling system automatically with ambient air before the pump is switched off.

5.1.5 The gas handling system shall be equipped with a gas flow meter, by which the user can check the measuring mode specified by the manufacturer of the gas analytical system.

5.1.6 The gas handling system shall be air-tight.

5.1.7 The gas analytical system may be equipped with an interface permitting it to be coupled to any peripheral devices or other instruments, e.g. facilities for measuring the characteristics of the flow gas in a pipe or gas duct.

The interface and peripherals coupled to it shall not affect the metrological characteristics of the gas analytical system or the measurement data obtained.

5.2 Display devices

5.2.1 Indication range of the gas analyzer

The indication range of the display device shall be from 0.0 ppm to the maximum measuring range. In normal operation the recording device may indicate 0.0 ppm for the volume fraction of SO₂ equal to or smaller than 1 ppm.

5.2.2 Interval and marks of the analog scale

In case of an analog scale, the distance between the scale marks shall be at least 1.25 mm. The interval of the marks shall be smaller than or equal to the 2 % of the span of the analog scale.

The thickness of the pointer shall not exceed one quarter of the distance between the scale marks. The pointer shall overlap at least one third of the shortest scale mark and shall be clearly seen.

The height of the figures shall be equal to at least 5 mm and they shall be marked in such a way that any misinterpretation would not be possible.

5.2.3 Digital display

5.2.3.1 The height of the figures shall be at least 5 mm.

5.2.3.2 The symbol of the unit of measurement shall appear in close proximity to the figures indicating the measurement results and the characters used shall be at least 3 mm in height.

5.3 Printing or recording device

When the analytical system has interfaces to submit analytical data, the gas analytical system shall be equipped with a printing device, which prints or records:

- the date and time at which the measurement result was received;
- the result of self-checking by means of automatic adjustment facilities;
- the measurement result (the printed result shall not differ from that which is indicated by the recording device);
- symbol of the units in which the result is expressed.

Note: In the case of continuous recording of the SO₂ concentration diagram on paper, the duration of recording shall be no less than that required for the report documentation.

Printouts shall remain readable for one month, even when exposed to daylight or equivalent lighting.

The legal authority may require that a printing device be provided. It may also require that more information appear on the printed document than requested above, e.g. the result of the volume fraction calculation during the specified period.

The printing device shall not print out an official report if the means of control have brought to evidence errors that exceed the maximum permissible errors, or failures. It shall also stop the measurement mode if no paper (or other recording medium) is available in the printing device.

5.4 Computing device

The gas analytical system can be equipped with a computing device (or a personal computer), which calculates emissions (e.g. the average emission during the specified time, etc.) and transmits their values with an **estimated uncertainty** to the printing device. The relevant authority shall certify the computational algorithm of the measurement results **and their estimated uncertainty**.

Since information about the flow rate, temperature, gas pressure and diameter of a pipe (gas duct) is necessary to calculate the stationary source emissions, it shall be provided with the required accuracy and automatically introduced into the computing device.

5.5 Alarming system

5.5.1 The gas analytical system may be equipped with an alarm system that shall give an audible or luminous signal when the maximum permissible single emission specified for the given stationary source is exceeded. The alarm system should be tested. A response error of the alarm system shall not exceed the maximum permissible errors according to 4.3.1.

The gas handling system shall have a device that measures or signals that the gas flow is not available or that its rate is outside the limits specified by the manufacturer.

5.5.2 An indication that the gas analytical system is ready for measurement shall be provided. If it is not ready, any indication on a recording device and any printing of the results on a printing device shall be prevented.

5.5.3 For a gas analytical system with electrochemical sensors, a warning device should be provided to signal that the effective life of the system has expired.

5.6 Adjustment facilities

5.6.1 The gas analytical system shall have adjustment facilities that provide readings for zero-setting, CGM and internal adjustment. The facilities may be manual, semi-automatic or automatic.

5.6.2 The internal adjustment shall neither affect the zero set, nor the instrument's linearity and it shall not be connected with the CGM adjustment. The approach should be such that each time a calibration gas mixture is applied to the input of the gas analyzer, the adjustment facilities will bring the readings into conformity with the value of the SO₂ volume fraction in the CGM.

5.6.3 The adjustment facility for zero-setting shall give negative indications near zero for certain tests or manual adjustment, if necessary.

5.6.4 The automatic adjustment facilities shall display or print out the results of all internal adjustments: flow rate (its deceleration), internal reference adjustment, calibration and leak immediately after switching on and then during operation with the periodicity specified by the operator.

5.7 Security of the gas analyzer operation

5.7.1 The technical means by which the gas analyzer is adjusted (particularly devices for adjusting the calibration with the CGM and zero-setting) shall not be accessible to the common operator or user.

5.7.2 The means used to change from one mode of operation to another shall be inaccessible to the common operator or user; access shall be possible only by entering a code, or by some other equivalent procedure.

5.8 Markings

One of the outer surfaces (or the “front surface”) of the gas analyzer in the gas analytical system shall be marked indelibly and irremovably with the following information:

- manufacturer’s name;
- symbolic notation of the gas analytical system;
- serial number;
- year of production;
- type approval mark;
- power supply parameters (voltage, frequency, power consumption).

The rear outer surface of the constituent part (unit) of the gas analytical system shall be marked with the following information:

- symbolic notation of the unit;
- serial number;
- year of production;
- gas analytical system to which it belongs;
- power supply parameters (voltage, frequency, power consumption).

6 Operating manual

6.1 The manufacturer shall provide an operating manual for each gas analytical system in the language(s) of the country in which it will be used.

6.2 The operating manual shall include:

- a) the time intervals and the procedures for adjustment and maintenance that shall be followed to comply with the established requirements;
- b) a list of possible malfunctions and methods of their repair;
- c) storage conditions;
- d) operating conditions.

7 Metrological controls

7.1 Type approval

7.1.1 Documentation

The documentation for a gas analytical system supplied by the manufacturer when applying for type approval shall include:

- a) a description of its general principle of measurement;
- b) a list of its essential components with their characteristics;
- c) a description of its essential components with drawings and diagrams;
- d) the general information on the software required for a microprocessor included in a gas analytical system;
- e) in case a calculation of SO₂ mass emission is included, a description of the applied formula with the values of the parameters and physical constants incorporated;
- f) the operating manual that shall be provided to the user to ensure reliable operation of the gas analytical system;
- g) a protocol of the preliminary tests, realized by the manufacturer.

It is advisable for the manufacturer to provide any data or other information confirming that the design, operation and characteristics of the gas analytical system comply with the requirements of this Recommendation.

7.1.2 General requirements

Type evaluation shall be carried out on at least one and normally not more than three samples of the gas analytical system. The evaluation shall be executed by means of tests.

7.1.3 External examination and tests

The external examination and testing of a gas analytical system is intended to verify compliance with the requirements of clauses 4, 5 and 6 of this Recommendation.

As a rule, tests should be carried out with a completely mounted gas analytical system. It is permitted to perform the test on a separate unit or device of the gas analytical system, if it is impossible to test the system as a whole due to its size or configuration, or when testing only the operation of a separate unit or device.

Tests of such a kind can be performed only in cases when it is possible to simulate the operating conditions for applying a separate unit or device included in a gas analytical system.

Note: It is not intended that separate components should be dismantled for when being tested.

The contents and metrological characteristics of calibration gas mixtures used during type approval shall conform to those specified in Annex B.

7.1.3.1 A gas analytical system shall undergo an external examination to obtain a general appraisal of its design and construction.

7.1.3.2 When testing a gas analytical system for its compliance with the requirements of clauses 4 and 5, the correctness of its functioning and compliance of the characteristics with the requirements of this Recommendation shall be checked (or the compliance of the characteristics obtained with those specified by the manufacturer).

7.1.3.3 The operating manual for a gas analytical system shall be checked to ensure that correct procedures are clearly indicated, especially those specified in 6.2.

7.2 Initial verification

7.2.1 General requirements

A new gas analytical system shall undergo initial verification only after type approval (depending on the legislation in each specific country). The verification shall be carried out using suitable testing means and calibration gas mixture.

7.2.2 External examination and tests

7.2.2.1 Initial verification of a gas analytical system includes an external examination to determine conformance with the approved type, and also compliance with the contents of the set of accompanying documents.

Note: The verification procedures should be approved by the responsible legal authority that carried out the type approval tests.

7.2.2.2 After adjusting a gas analytical system according to the routine adjustment procedure described in the operating manual, tests to determine its errors shall be carried out under rated operating conditions at several values over the measuring range.

The tests shall be performed using at least three calibration gas mixtures (CGMs) with values of the SO₂ volume fractions that are uniformly distributed over the measurement range.

The smallest and the largest values of the SO₂ volume fraction in a CGM shall not differ from the lower and upper values of the measurement range by more than + 10 % and – 10%, respectively.

The uncertainty on the SO₂ volume fraction of the CGM shall be such that the ratio between the moduli of the uncertainty of the CGM and the maximum permissible error of the gas analytical system at the given point of the measurement range shall be not more than 1:3. The responsible legal authority may allow the ratio 1:2.

The errors observed during the tests shall be within the permissible limits according to 4.3.2 for initial verification at each measurement.

7.3 Subsequent verification

The responsible legal authority shall provide instructions with requirements giving:

- the content and volume of subsequent verifications;
- recalibration intervals; and
- recommendations for on-line testing indicated in the operating manual.

8 Performance tests for type approval

Prior to the type approval tests and when specified by the manufacturer, gas analytical systems shall be calibrated against the CGM according to the operating manual procedures and under reference conditions (if not specified otherwise):

- a) temperature: 20 °C ± 5 °C;
- b) relative humidity: 60 % ± 10 %;
- c) ambient pressure: 86 kPa to 106 kPa, stable ± 1 kPa;
- d) supply from AC mains power:
 - voltage: nominal voltage ± 2 %;
 - frequency: nominal frequency ± 1 %;
- e) presence of influencing gas components: none;
- f) vibrations: none;
- g) radiated, radio-frequency: electromagnetic fields < 0.2 V/m;
- i) conducted radio-frequency fields: 0.2 V emf;
- j) electrostatic discharge: none;
- k) power frequency magnetic field: < 1 A/m;
- l) bursts (transients) on signal, data and control lines: negligible;
- m) surges on signal, data and control lines: negligible;
- n) AC mains voltage dips, short interruptions and voltage variations: none;
- o) bursts (transients) on AC and DC main: negligible;
- p) surges on AC and DC mains power: none.

8.1 Determination of the intrinsic error of the gas analyzer

This test shall be carried out according to A.2, under reference conditions. During this test, the errors shall not exceed the maximum permissible intrinsic error of 4.3.1 for any measurement.

8.2 Stability with time or drift

This test shall be carried out according to A.3, under reference conditions. During this test the requirements of 4.9 shall be met.

8.3 Repeatability

This test shall be carried out according to A.4, under reference conditions. For 20 consecutive measurements of one and the same CGM, made by one and the same operator using one and the same gas analytical system during a short period of time, the standard deviation shall not exceed 1/3 modulus of the maximum permissible error according to 4.4, for the relevant point of the measurement range.

8.4 Effect of influence quantities

As a rule, only one influence quantity shall be varied during a test while all the others are maintained at their reference values.

8.4.1 Environmental conditions and electrical supply

The reading change of the gas analytical system shall remain within the maximum permissible error given in operating manual, during the following tests covering the rated operating conditions in 4.5.2:

- a) dry heat: A.5
- b) cold: A.6
- c) damp heat, steady state: A.7
- d) atmospheric pressure: A.8
- e) power supply variations: A.9

8.4.2 Influence of gas components other than the measurand (cross sensitivity)

This test shall be carried out under reference conditions according to 4.5.1, except for (e). During this test (A.10) the volume fraction of gas components other than the measurand in CGM shall correspond to that specified in 4.5.3. The absolute value of the variation of the reading shall not exceed the value given in 4.5.3.

8.4.3 Vibration stability of the gas analytical system

This test shall be carried out under reference conditions according to 4.5.1, except for (f). During this test (A.11.1) the absolute value of the reading variation shall not exceed the value given in the operating manual.

8.5 Disturbances

The error of the gas analytical system shall be within the permissible limits specified in 4.3.2, or significant faults shall be detected and fixed by means of checking facilities during the following tests, carried out to verify the requirements of 4.6 under rated operating conditions (as specified in 4.5.2):

- a) mechanical shock: A.11.2
- b) short time power reduction: A.12
- c) bursts from the mains (transients): A.13
- d) electrostatic discharges: A.14
- e) radio frequency electromagnetic fields: A.15

8.6 Other important technical requirements

The gas analytical system shall be tested for conformity to the following requirements:

- a) warm-up time: according to 4.8 and A.16;
- b) response time: according to 4.7 and A.17
- c) change in the gas flow rate (in a gas handling system): according to 5.1.5, 5.5.2 and A.18
- d) leakproofness of the gas handling system: according to 5.1.6, 5.5.2 and A.19.

Annex A

Performance tests for type approval

(Mandatory)

A.1 General

Prior to the type approval tests, the referenced documents shall be studied.

A.2 Error determination

For the linear calibration characteristic, the error of a gas analytical system shall be determined for at least three points within the measuring range and sub-range. It is recommended to use a calibration gas mixture (CGM) with the following values of SO₂ volume fractions:

- minimum value of the measuring range + 10 %;
- average value ± 10 %;
- maximum value of the measuring range – 10 %.

In the case of a nonlinear calibration characteristic, the error shall be determined for at least five points uniformly distributed within the measuring range and sub-range.

Measurements at each point of the measurement range shall be repeated at least three times, and no errors should be greater than the specified limits.

A.3 Stability with time or drift

This test shall be conducted for a period of seven days following the warm-up time. Measurements shall be performed at least every 24 hours using a CGM with the largest and the smallest SO₂ volume fractions according to A.2.

A.4 Repeatability

The test procedure specified in 8.3 shall be carried out with each of the CGMs recommended in A.3.

An estimate of the standard deviation is given by the formula:

$$s = \sqrt{\frac{\sum_{i=1}^n (Y_i - \bar{Y})^2}{n-1}}$$

where:

n is the number of measurements, $n = 20$;

Y_i is the i^{th} indication of the gas analytical system;

\bar{Y} is the arithmetic mean of the n values.

A.5 Dry heat

A.5.1 This test consists of exposure of the gas analytical system (or its separate components) to a temperature of 40 °C (or at the maximum operating temperature specified by the manufacturer) for 2 hours. The time duration begins after the gas analytical system (or its component) has reached temperature stability. The change in temperature shall not exceed 1 °C/min during heating up and cooling down, and the relative humidity shall not exceed 50 %.

A.5.2 The calibration gas mixture shall be supplied to the sampling probe at ambient pressure (with a deviation of ± 0.8 kPa). During the test one measurement shall be performed every half-hour using each of the CGMs recommended in A.3.

References: IEC Publication 60068-2-2 [8], IEC 60068-3-1 [25] and OIML D 11:2004 [6], 10.1.1.

A.6 Cold

A.6.1 This test consists of exposure of the gas analytical system (or its separate components) to a temperature of 5 °C (or at the minimum operating temperature specified by the manufacturer) for 2 hours. The time duration begins after the gas analytical system (or its component) has reached temperature stability. The change in temperature shall not exceed 1 °C/min during cooling down and heating up. The relative humidity shall not exceed 50 %.

A.6.2 The CGM shall be supplied to the sampling probe at ambient pressure (with a deviation of ± 0.8 kPa). During the test one measurement shall be performed every half-hour using each of the CGMs recommended in A.3.

References: IEC 60068-2-1 [7], IEC 60068-3-1 [25] and OIML D 11:2004 [6], 10.1.2.

A.7 Damp heat, steady state

A.7.1 This test consists of exposure of the gas analytical system to a constant temperature of 30 °C and a constant relative humidity of 85 % for 2 days. The exposure shall be such that water does not condense on the gas analytical system. The temperature is deemed to be steady when the difference between the extreme temperatures does not exceed 5 °C, and the rate of change does not exceed 5 °C/h.

A.7.2 The CGM shall be supplied to the sampling probe at ambient pressure (with a deviation of ± 0.8 kPa). During the test one measurement shall be performed every day using each of the CGMs recommended in A.3.

References: IEC 60068-2-78 [12], IEC 60068-3-4 [26] and OIML D 11:2004 [6], 10.2.1.

A.8 Ambient pressure

A.8.1 The test consists in determining the error of the gas analytical system under the extreme pressures of the rated operating conditions or extreme pressures specified by the manufacturer if they are outside the limits in 4.5.1. The extreme values shall be reached gradually from stable ambient

pressure conditions and shall be kept at the stable maximum permissible level during 30 min before starting the measurements as specified in A.8.2.

A.8.2 The calibration gas mixture shall be supplied to the sampling probe at ambient pressure (with a deviation of ± 0.8 kPa). At least two measurements shall be performed at each extreme pressure value using each of the CGMs recommended in A.3.

Note: If an automatic or semi-automatic pressure compensation is provided for in the gas analytical system, then care must be taken to ensure that measurements at both extreme pressure values are performed after completing this process.

A.9 Power supply variation

A.9.1 The AC power supply test consists of exposure of the gas analytical system to extreme values of the nominal power supply voltage and nominal frequency according to 4.5.2 for a period long enough to perform the required measurement.

A.9.2 At each extreme value of the power supply parameters, measurements shall be carried out using the CGM with the largest SO₂ volume fraction according to A.2.

A.10 Influence of gas components other than SO₂ (cross sensitivity)

The influence shall be determined by registering the measuring signal when the following gas mixtures are supplied to the input:

- zero gas N₂; then
- each influencing gas alone in N₂; and finally
- each influencing gas together with SO₂ in N₂.

The concentration (volume fraction) of each influencing gas shall correspond to the limit value specified by the manufacturer.

Note: A responsible legal authority may take the decision to include some other components in the test.

A.11 Mechanical vibrations and shock

A.11.1 For vibration testing, the gas analytical system or its separate components shall be mounted on a vibrating table and shall be fixed rigidly in the operating position. During the test, the gas analytical system shall be in the operating mode, the CGM with the largest SO₂ volume fraction according to A.2 being supplied to the input. The vibration parameters shall correspond to those specified by the manufacturer. The testing conditions shall correspond to the reference conditions in paragraph 8. Minimum requirements for vibration should correspond to 4.5.3.

A.11.2 For mechanical shock testing, the gas analytical system or its separate component shall be placed in its normal position of use on a rigid surface. The component (gas analytical system) shall be tilted on one bottom edge and then shall be allowed to fall freely onto the test surface. The following conditions shall be applied:

Height of fall 25 mm;
Number of falls..... 1 on each bottom edge.

A.11.2.1 Before and after the test, the error of the gas analytical system shall be determined using the CGM with the largest SO₂ volume fraction according to A.2.

References: IEC 60068-2-47 [10], IEC 60068-2-64 [11], IEC 60068-3-8 [13], IEC 60068-2-31[9] and OIML D 11:2004 [6], 11.1.1 and 11.2.

A.12 Short-time power reduction

A.12.1 A test generator suitable to reduce the amplitude of the AC mains voltage is used. It shall be adjusted before being connected to the gas analytical system. The mains voltage interruptions and reductions shall be repeated 10 times with an interval of at least 10 s between successive disturbances. The following conditions shall be applied:

Reduction factor	Duration
100 %	10 ms
50 %	20 ms

A.12.2 During the test, measurements shall be performed using the CGM with the largest SO₂ volume fraction according to A.2.

References: IEC 61000-4-11 [19] and OIML D 11:2004 [6], 13.4.

A.13 Voltage pulses from the mains

A.13.1 The test consists in affecting the gas analytical system with pulses of amplitude 1.0 kV, which have the form of a double exponent. Each pulse shall have a rise time of 5 ns and half amplitude duration of 50 ns. The pulse duration shall be 15 ms and the period of their repetition shall be 300 ms. The repetition frequency of the impulses and peak values of the output voltage on a 50 Ω load shall be (5 ± 1) kHz. The transient generator shall have an output impedance of 50 Ω and shall be adjusted before connecting the gas analytical system. At least 10 positive and 10 negative pulses randomly phased shall be applied. Insertion of blocking filters in the cables to the gas analytical system may be necessary to prevent the pulse energy being dissipated in the mains.

A.13.2 During the test, measurements shall be performed using the CGM with the largest SO₂ volume fraction according to A.2.

References: IEC 61000-4-4 [16], IEC 61000-4-5 [17] and OIML D 11:2004 [6], 13.5.

A.14 Electrostatic discharges

A.14.1 A capacitor of 150 pF shall be charged by a suitable DC voltage source of 6 kV in contact mode and 8 kV in air mode. Then it shall be discharged through the gas analytical system (separate component) by connecting one terminal to the system's ground chassis and the other through a 330 Ω resistance to the system's surfaces that are normally accessible to the user. At least 10 successive discharges shall be applied with a time interval between discharges of at least 10 s. A gas analytical system (component or unit) not equipped with a grounding terminal (for which earthing is not

provided) shall be placed on a grounded plane surface that projects beyond the gas analytical system (component or unit) by at least 0.1 m on all sides. The associated grounded connection to the capacitor shall be as short as possible.

A.14.2 In the contact discharge mode, to be carried out on the conductive surfaces, the electrode shall be in contact with the gas analytical system (component or unit) and the discharge shall be actuated by the discharge switch of the generator. In the air discharge mode, on insulating surfaces, the electrode is approached to the gas analytical system (component or unit) and the discharge occurs by spark.

A.14.3 During the test, measurements shall be performed using the CGM with the largest SO₂ volume fraction according to A.2.

References: IEC 61000-4-2 [14] and OIML D 11:2004 [6], 12.2.

A.15 Radiated, radio frequency, electromagnetic fields

A.15.1 The gas analytical system (component) shall be exposed to electromagnetic field strength as follows:

- frequency range: 26 MHz – 1000 MHz;
- field strength: 3 V/m;
- modulation: 80 % AM, 1 kHz sine wave.

A.15.2 The field strength may be generated in the following ways:

- a) a strip line for low frequencies for small components of the gas analytical system from DC to 150 Hz;
- b) a TEM cell (Transverse Electromagnetic Mode cell) for higher frequencies, up to 1 GHz;
- c) a biconical antenna (26 MHz – 300 MHz);
- d) a log periodic antenna (100 MHz – 1000 MHz).

The specified field strength shall be established prior to the actual testing (without the gas analytical system or its component in the field).

When the test is carried out in a shielded enclosure to comply with international laws prohibiting interference to radio communications, care needs to be taken to handle reflections from walls. Anechoic shielding may be necessary.

A.15.3 During the test, measurements shall be performed using the CGM with the largest SO₂ volume fraction according to A.2.

References: IEC 61000-4-3 [15] and OIML D 11:2004 [6], 12.1.1.

A.16 Warm-up time

A.16.1 At reference conditions and at 5 °C, the warm-up time test to verify compliance with 4.8 shall consist of the following steps:

- a) stabilize the gas analytical system at each temperature;
- b) let the gas analytical system warm up;
- c) immediately after either the manufacturer's prescribed warm-up period has elapsed or an automatic warm-up lockout has been de-activated, perform an SO₂ volume fraction measurement (with any necessary internal adjustment being performed prior to this measurement). Each of the CGMs recommended in A.3 shall be used;
- d) at time intervals of 2, 5 and 15 min after warm-up, perform a measurement with each of the CGMs recommended in A.3 as in step c).

A.16.2 The difference between any of the 4 measured values in c) and d) in A.17.1 shall not exceed 0.25 modulus of the maximum permissible error on initial verification.

Note: At reference conditions, the warm-up time test may be included with the drift test.

A.17 Response time

A.17.1 When testing, the time required for a gas analytical system to be able to perform measurements with a given accuracy (4.3.1) is determined when at the input of a sampling device ambient air is replaced with a sample containing SO₂. Some means shall be applied to perform such instant replacement. The gases shall be supplied to the sampling device at the ambient pressure (± 750 Pa). The response time shall not exceed the appropriate values specified in 4.7.

A.17.2 During the test, measurements shall be performed using the CGM with the SO₂ volume fraction equal to 90 % of the maximum value of the measuring range and sub-range (see 4.7).

A.18 Spillover of gas flow rates

A.18.1 A measurement shall be performed with a calibration gas mixture that is initially supplied at the sampling device at a gas flow rate greater than the minimum required by the gas analytical system according to the manufacturer. During the measurement, the gas flow rate shall be reduced until the low flow indicator responds according to the requirements of 5.1.5 and gives a signal according to the requirement of 5.5.2.

A.18.2 The test is repeated according to A.19.1, but starting from a gas flow rate smaller than the maximum required by the gas analytical system according to the manufacturer. During the measurement, the gas flow rate shall be increased until the flow rate indicator responds according to the requirements of 5.1.5 and gives a signal according to the requirement of 5.5.2.

A.18.3 During the test, measurements shall be performed using each of the CGMs recommended in A.3.

A.19 Leak-proofness

The compliance of leak-proofness of the gas analytical system with 5.1.6 is determined using the pressure-gauge (compression or vacuum) method according to IEC 60068-2-17-94 [27] as described in the operating manual.

Annex B

Designation of calibration gas mixtures and their composition

(Mandatory)

B.1 General requirements

B.1.1 The CGM shall be supplied either from a gas cylinder under pressure or from a gas mixture generator.

a) Each gas cylinder shall be identified with the following information (included as a mark, label, and/or certificate):

- manufacturer of the gas cylinder and serial number;
- composition of the gas mixture;
- temperature limits for use and storage;
- date of certification and expiry date;
- name of the authority that carried out the certification;
- the marking “calibration gas mixture”; and
- the method of preparation: gravimetric according to ISO 6142 [28] and ISO 6143 [29].

b) The gases obtained from the gas mixture generator using the dynamic method shall meet the requirements of ISO 6145-1 [30] and in addition the requirements of B.1.2 and B.2.

B.1.2 The composition of the CGM used for type approval and verification shall be certified as complying with the requirements of B.2 by a competent authority, the unit of SO₂ volume fraction being traceable to national, regional or international standards.

B.1.3 For all other purposes the CGMs (except those indicated in B.1.2) shall be certified by the supplier of the gases and shall be traceable to the appropriate measurement standards.

B.1.4 For testing with the purpose of determining errors, three binary gas mixtures containing SO₂ in N₂ with an SO₂ volume fraction, corresponding to the range points of (5 + 5) %, (50 ± 5) % and (95 – 5) %, are used.

For cross sensitivity testing, the gas mixtures with the maximum content of influencing components, other than the measurand are used.

B.1.5 The material of gas cylinders shall be inert to the gases contained therein.

B.1.6 The appropriate safety regulations shall be followed when handling the gases.

B.2 Characteristics and uncertainties of the composition of the gas mixtures

B.2.1 The SO₂ volume fraction in N₂ in cylinders or in a gas mixture obtained from the generator shall be given in parts per million, ppm (see 4.1).

B.2.2 The blend tolerances of the calibration gas mixtures shall not exceed 10 % of the volume fraction of each component.

B.2.3 For calibration gas mixtures the uncertainty in the composition shall be ± 2 % or less of the certified (assigned) value of SO₂ volume fraction. The composition of other gas mixture components shall have an uncertainty of no more than ± 3 %.

B.3 Zero setting

Ambient air shall be drawn through a charcoal filter or equivalent system when it is used to set zero for the gas analytical system.

Annex C

Procedure for initial verification

(Mandatory)

The initial verification of a gas analytical system should include the following tests:

- C.1** Check the power supply voltage and frequency at the location of use to determine compliance with the manufacturer's specifications.
- C.2** Check the activation of the warm-up lockout by attempting to make a measurement prior to the operating mode.
- C.3** After the gas analytical system has warmed up, determine its error as described in 7.2.2.2.
- C.4** Check the air-tightness of the system by performing a leak check as described in A.19.
- C.5** Check for the activation of the gas flow rate device (unit) as described in A.18.2.
- C.6** Check the response time as described in A.17.

Annex D

Procedure for subsequent verification

(Informative)

Subsequent verification of a gas analytical system at the same location may include the following tests:

- D.1** For short-term subsequent verification, perform all tests included in the initial verification except for the power check and the warm-up check.
- D.2** For short-term subsequent verification, determine the error using the number of CGM required for initial verification, unless the responsible legal authority specifies fewer CGM.
- D.3** For long-term subsequent verification, perform all tests included in the initial verification.
- D.4** When a gas analytical system has been moved to a new location, or has undergone repairs other than the replacement of components (e.g. a sampling device or a filter) as defined in the manufacturer's operating manual, perform all tests included in the initial verification.

Annex E

Procedure for gas analytical system control under operating conditions

(Informative)

E.1 Perform an internal adjustment check of the gas analytical system that may include checking the gas flow rate, the temperature of the heated gas-mains at intervals specified by the responsible legal authority or recommended in the manufacturer's operating manual.

E.2 Determine the error of the gas analytical system and internal adjustment with one CGM at intervals specified by the responsible legal authority or recommended in the manufacturer's operating manual.

E.3 Perform a leak check of the gas handling system at least once a day. Repair any leakage/leak and perform a successful leak check before measurement.

E.4 Perform a leak check after each disassembly of the gas handling system (e.g. a sampling device or filter element replacement). Repair any leakage/leak and perform a successful leak check before measurement.

Annex F

Evaluation Report Format

Introduction

The *Evaluation Report Format* aims at presenting, in a standardized format, the results of the various tests and examinations to which a type of a gas analytical system shall be submitted with a view to its approval.

In the framework of the OIML Certificate System for Measuring Instruments, use of the *Evaluation Report Format* is mandatory.

Report NoOIML Recommendation No..... Edition (year)

F.1 Name and address of the testing laboratory(ies)

.....
.....
.....
.....

**F.2 Location at which tests were performed
(if other than the address identified in F.1)**

.....
.....
.....
.....

F.3 Name and address of the manufacturer

.....
.....
.....
.....

F.4 Name and address of the applicant (if other than the manufacturer)

.....
.....
.....
.....

F.5 Identification of the type tested

Trade name:

Model No.:

Serial No.:

Brief description (if useful, including reference to diagrams and inscriptions)

.....
.....
.....
.....

F.5.1 Composition of the type tested (the main components of the gas analytical system are to be listed. If the component is purchased, its name, model, serial No. and manufacturer are to be specified):

.....
.....
.....
.....
.....

F.6 Visual and technical examination (*see below*)

F.7 Conclusion of the tests (*see below*)

F.8 Test method

In the case where this Recommendation indicates a recommended test number or recommended test values, these numbers and values shall be used in the framework of the *OIML Certificate System*.

The test report shall indicate what test means were used. Where test means did not conform to this Recommendation, their necessary metrological and technical characteristics shall be given.

Where this Recommendation offers an alternative, the assurance of its requirements shall be indicated. Any arguments or results of tests necessary to demonstrate the equivalence of results shall be given.

Any problem (fault to be repaired) observed during tests shall be mentioned.

Any useful information about test conditions (ambient temperature, humidity, etc.) shall be indicated.

F.9 Brief statement on general conclusion as to whether the samples tested meet the requirements of this Recommendation

.....
.....
.....
.....

F.10 Person(s) responsible for the testing

Signature(s) Date

Title(s)

Visual and technical examination report (F.6)

Reference to this OIML Recommendation	Requirements indicated in the operating manual	Actual results	Consistent /inconsistent with	Comments
Unit of measurement	4.1			
Measuring range	4.2			
Range of readings	5.2.1			
Registering device	5.2.2			
	5.2.3			
Printing device	5.3			
Computing device	5.4			
Signaling device	5.5.1			
	5.5.2			
	5.5.3			
Adjustment facilities	5.6.1			
	5.6.2			
	5.6.3			
	5.6.4			
Warm-up time	4.8			
Response time	4.7			
Air-tightness of the gas handling system	5.1.6			
Security of operation of the gas analyzer	5.7.1			
	5.7.2			
	5.7.3			
Markings	5.8			

Put a cross × in the appropriate column(s).

Comments may be developed separately if necessary.

Conclusion of the tests (F.7)

Reference to this OIML Recommendation	Requirements indicated in the operating manual	Actual results	Consistent /inconsistent with	Comments
Intrinsic error	4.3.1			(1)
Repeatability	4.4			(1)
Drift	4.9			(1)
Cross sensitivity	4.5.2			
Physical influence factors	AC supply voltage			
	supply frequency			
	DC supply voltage			
	temperature			
	humidity			
	pressure			
	vibrations			
Disturbances 4.6 Annex A	A.11.2 mechanical shock			
	A.12 short time power reduction			
	A.13 voltage pulses from the mains			
	A.14 electrostatic discharges			
	A.15 radio frequency electromagnetic fields			
	A.16 Mains frequency magnetic fields			

Annex G

Bibliography

- [1] OIML V 2-200 “International Vocabulary of Metrology – Basic and General Concepts and Associated Terms (VIM), 2007
- [2] Guide to the expression of uncertainty in measurement (GUM). BIPM, IEC, IFCC, ISO, IUPAC, IUPAP and OIML. ISO, Geneva, 1995
- [3] International vocabulary of terms in legal metrology (VIML). OIML, Paris, 2000
- [4] The International System of Units (SI), 8th edition, BIPM, Paris, 2006
- [5] International Document OIML D 2: Legal units of measurement, OIML, Paris, 1999 + Amendment 2004
- [6] International Document OIML D 11: General requirements for electronic measuring instruments. OIML, Paris, 2004
- [7] IEC 60068-2-1 (2007-03) Environmental testing, Part2: Tests, Test A: Cold.
- [8] IEC 60068-2-2 (1974-01), with amendments 1 (1993-02) and 2 (1994-05) Environmental testing Part2: Tests. Test B: Dry heat.
- [9] IEC 60068-2-31 (2008-05) Environmental testing - Part 2-31: Tests - Test Ec: Rough handling shocks, primarily for equipment-type specimens.
- [10] IEC 60068-2-47 (2005-04) Environmental testing Part 2-47: Test methods, Mounting of components, equipment and other articles for vibration, impact and similar dynamic tests.
- [11] IEC 60068-2-64 (1993-05), with Corrigendum 1(1993-10) Environmental testing - Part 2: Test methods, Test Fh: Vibration, broad-band random (digital control) and guidance.
- [12] IEC 60068-2-78 (2001-08) Environmental testing - Part 2-78: Tests - Test Cab: Damp heat, steady state.
- [13] IEC 60068-3-8 (2003-08) Environmental testing - Part 3-8: Supporting documentation and guidance - Selecting amongst vibration tests.
- [14] IEC 61000-4-2 (1995-01) with amendment 1 (1998-01) and amendment 2 (2000-11) Basic EMC Publication Electromagnetic compatibility (EMC) Part 4: Testing and measurement techniques, Section 2: Electrostatic discharge immunity test. Consolidated Edition: IEC 61000-4-2 (2001-04) Ed. 1.2.
- [15] IEC 61000-4-3 (2006-02) Electromagnetic compatibility (EMC): Part 4-3: Testing and measurement techniques - Radiated, radio-frequency, electromagnetic field immunity test.
- [16] IEC 61000-4-4 (2004-07) with corrigendum 1 (2006-08) Electromagnetic compatibility (EMC) - Part 4: Testing and measurement techniques - Section 4: Electrical fast transient/burst immunity test. Basic EMC Publication.
- [17] IEC 61000-4-5 (2005-11) Electromagnetic compatibility (EMC) - Part 4-5: Testing and measurement techniques - Surge immunity test.

- [18] IEC 61000-4-6 (2003-05) with amendment 1 (2004-10) and amendment 2 (2006-03) Electromagnetic compatibility (EMC): Part 4: Testing and measurement techniques, Section 6: Immunity to conducted disturbances, induced by radio-frequency fields. Consolidated Edition: IEC 61000-4-6 (2006-05) Ed. 2.2.
- [19] IEC 61000-4-11 (2004-03) - Part 4-11: Testing and measuring techniques - Voltage dips, short interruptions and voltage variations immunity tests.
- [20] IEC 61000-6-1 (2005-03) Electromagnetic compatibility (EMC) - Part 6-1: Generic standards - Section 1: Immunity for residential, commercial and light-industrial environments.
- [21] IEC 61000-6-2 (2005-01) Electromagnetic compatibility (EMC) - Part 6-2: Generic standards - Immunity for industrial environments.
- [22] ISO 7504 “Gas analysis – Vocabulary”, 2001
- [23] ISO 10396 “Stationary source emissions – Sampling for the automated determination of gas concentrations”, 2007
- [24] ISO 31-8-1992 “Quantities and units – Part 8: Physical chemistry and molecular physics”.
- [25] IEC 60068-3-1 (1974-01) Environmental testing - Part 3: Background information - Section One: Cold and dry heat tests
- [26] IEC 60068-3-4 (2001-08) Environmental testing - Part 3-4: Supporting documentation and guidance - Damp heat tests
- [27] IEC 60068-2-17 (1994-07) Basic environmental testing procedures – Part 2: Tests – Test Q: Sealing.
- [28] ISO 6142 “Gas analysis – Preparation of calibration gas mixtures – Gravimetric method”, 2001
- [29] ISO 6143 “Gas analysis – Comparison methods for determining and checking the composition of calibration gas mixtures”, 2001
- [30] ISO 6145-1 “Gas analysis – Preparation of calibration gas mixtures using dynamic volumetric methods – Part 1: Methods of calibration”, 2003